



Design of Instrumentation System for Piezoelectric-Based Rainfall Power Generation

Jotje Rantung ^{a,*}, Benny Maluegha ^a, Yan Tondok ^a, Gideon David Rantung ^b

^a Department of Mechanical Engineering, Sam Ratulangi University, Manado-95115, Indonesia

^b Department of Computer Science, Asia Pacific University of Technology and Innovation (APU), Kuala Lumpur 57000 Malaysia.

* Corresponding Author Email: jrantung@unsrat.ac.id

DOI: <https://doi.org/10.54392/irjmt25318>

Received: 05-09-2024; Revised: 20-03-2025; Accepted: 05-04-2025; Published: 14-05-2025



Abstract: This research presents the systematic design, implementation, and evaluation of a piezoelectric-based instrumentation system for energy harvesting from precipitation events. Utilizing Lead Zirconate Titanate (PZT) transducers, signal conditioning via an LM741 operational amplifier, and an Arduino Mega2560 microcontroller for data acquisition and control, the system converts the mechanical energy of raindrop impacts into electrical output. Laboratory simulations were conducted under controlled variations in water droplet height (170–270 cm) to evaluate the electrical response in both series and parallel transducer configurations. Experimental results demonstrated peak output voltages of 2.68 V and 2.66 V for series and parallel configurations, respectively. Measurement system evaluation using Gage Repeatability and Reproducibility (Gage R&R) analysis revealed a total system variability of 4.36% (series) and 1.89% (parallel), confirming high measurement precision and robustness. Despite the low-voltage nature of the generated power, the system validates the feasibility of utilizing rainfall as a renewable energy source for low-power applications. Future research will focus on enhancing energy conversion efficiency through advanced piezoelectric materials, optimized circuit topology including DC-DC boost converters, and integration with high-capacity energy storage modules such as supercapacitors. Moreover, real-time performance monitoring via IoT-based platforms and hybridization with solar or wind systems is proposed for broader applicability.

Keywords: Instrumentation System, Piezoelectric Sensors, Rainfall energy, Energy Harvesting, Gage R&R.

1. Introduction

Electrical energy is generally obtained by converting coal, gas, and fossil fuels into heat and driving turbines and generators to produce electricity. Energy from coal, gas, and fossil fuels is limited and expensive. Efforts to produce alternative electrical energy are essential in overcoming challenges related to climate change, resource depletion, and environmental impacts. Various methods and technologies are being explored and developed to generate electricity from alternative and sustainable sources. Mechanical vibrations, thermoelectric power, acoustic energy, and solar energy can all be harnessed to produce electricity using energy harvesters. Piezoelectric materials generate electricity when they are deflected [1]. Piezoelectric materials utilize the direct piezoelectric effect to transform vibrations into energy. Raindrops can cause vibrations, which piezoelectric materials can turn into electricity.

The conversion of raindrops into piezoelectric-based electrical energy is not a new notion. The effect of raindrops on piezoelectric materials has been

extensively explored in recent years. Theoretical studies were conducted [2], experimentally [3], and simulation [4]. This research aims to test how much impact raindrops have on piezoelectric materials to produce electrical energy. Sensors are constructed from two types of piezoelectric materials: lead zirconate titanate (PZT) piezoelectric ceramic and polyvinylidene difluoride (PVDF). Vatansver et al. investigated the impact of water droplets with masses of 50 mg and 7.5 mg at varying heights on PVDF and PZT composite structures. The maximum peak voltage produced by PVDF and PZT cantilever structures is 12 V and 3 V, respectively. Viola *et al.* [5] investigated the behavior of a single water droplet hitting a PVDF beam. Simulation and experimental data demonstrate that a water droplet weighing 0.12 g and falling from a height of 0.8 m can generate a peak voltage of 6 V. Simulation and experimental data demonstrate that a water droplet weighing 0.12 g and falling from a height of 0.8 m can generate a peak voltage of 6 V. Ahmad et al. conducted another experiment that examined the impact of a single water droplet on a five-layer PZT cantilever beam [6]. Research has proven that piezoelectric materials have

the ability to generate electricity through the piezoelectric effect. This could bring important contributions to the development of renewable energy sources and more advanced sensor technologies. Nevertheless, the practical use of piezoelectric materials in energy applications still requires further development to overcome some technical challenges and improve their efficiency.

The piezoelectric sensor produces vibration energy received from raindrops, which forms a force on the piezoelectric surface. At the same time, the piezoelectric sensor functions as a generator, converting mechanical energy into electrical energy [7–10]. Piezoelectric sensors convert kinetic energy from mechanical vibrations into an AC source [11–13]. As a result, an AC/DC converter circuit is necessary for power storage, as the majority of standalone applications operate on a DC power source. Electronic circuit design can be thoroughly investigated, including voltage multipliers, AC/DC converters, and charging. Therefore, it is required to build an appropriate mix of piezoelectric configurations that extract low frequency vibrations in order to determine the optimal piezoelectric sensor configuration for collecting low frequency vibration energy. Previous study indicated that low frequency applications can be found in vibration sources [14]. However, several issues arise as a result of inconsistent vibration caused by a variety of parameters, including pressure amplitude, frequency of movement against the piezoelectric surface plate, and disk displacement. Furthermore, the circuit design for extracting vibrations must be stable, compatible, and trustworthy with the source vibration of piezoelectricity and consistency. As a result, there is a considerable challenge in selecting an appropriate arrangement configuration, meaning series, parallel, or a combination of both for circular piezoelectric in order to produce optimal low frequency vibrations [15–18]. Apart from that, several obstacles to piezoelectric sensors are magnetoelectric effects [19]. The magnetoelectric effect can be magnified using strain transfer between the piezoelectric and magneto restrictive constituents without any loss of value at all. This magnetoelectric effect is generally used to regulate electricity at operating frequencies. Ideal strain transfer generally cannot occur in composite materials because of the influence of the quality of the material in each layer and the quality of the interface. Implementation of LabVIEW software-based instrumentation for energy harvesting from piezoelectric based on a cantilever structure. However, this work is carried out for monitoring purposes. Zhe Wangi *et al.* [20] provided a holistic review of the development of energy harvesting techniques using piezoelectric materials. The development was in the form of electronic design to optimize the conversion of mechanical energy into electrical energy, wireless devices, or battery charging. With a deep understanding of these aspects, researchers can develop more effective strategies to

optimize piezoelectric energy harvesting in converting mechanical energy into electrical energy.

Piezoelectric materials can degrade over time, especially if subjected to high pressure or vibration. Energy conversion efficiency can decrease due to these factors. In instrumentation design, consideration must be given to the long-term stability of the piezoelectric material used, as well as protection from environmental conditions that may affect performance. Furthermore, piezoelectric produce small electrical signals, which require highly sensitive signal amplification and signal processing systems for applications such as vibration detection or pressure measurement. To improve the efficiency of piezoelectric instruments, the design must ensure that the instrumentation system is able to overcome noise and optimize signal accuracy without compromising measurement quality. Overall, the piezoelectric efficiency challenge is directly related to instrumentation design, as good design will optimize the performance of the piezoelectric system, overcome efficiency limitations, and extend the operational life of the device.

The limitations of piezoelectric sensors can be solved by including a suitable instrumentation system that generates electricity from piezoelectric sensor-based rainfall. To generate electricity automatically using piezoelectric sensors, the instrumentation system must be integrated with a hardware structure that includes frequency filters, signal amplifiers, and recording devices, physical shields to protect the sensors from harsh environments, and storage of the generated electrical energy. The instrumentation system must be constructed to yield accurate data from piezoelectric sensors. In this research, an electrical energy harvesting system will be designed by adding a data acquisition system. For this purpose, it will exploit the potential of an open-source prototype system based on piezoelectric Arduino microcontrollers. This research began with measurement instrumentation design, prototyping, and laboratory testing.

This study presents an innovative approach in utilizing piezoelectricity as an alternative energy source from rainfall. The main innovations include the use of Arduino Mega2560 for real-time system control, integration of high impedance amplifier circuits for voltage stabilization, and experimental simulations with varying heights to test energy efficiency. This study also analyses series and parallel configurations for optimizing output voltage, and proposes the use of a boost converter so that the voltage can be applied practically. In addition, a data processing and data log approach is applied to overcome data loss and sensor interference. Overall, this study makes a significant contribution to the development of a more reliable, efficient, and applicable piezoelectric renewable energy system.

The objective of this research is to design a piezoelectric-based power generation instrumentation

system from rainfall. Selecting and integrating instrumentation systems according to the needs of electricity generating applications can help overcome the weaknesses of piezoelectric sensors and improve their performance in various operational conditions.

2. Proposed Instrumentation System

This stage explains the concept of designing a piezoelectric sensor instrumentation system to convert rainfall into electrical energy, using a schematic circuit model of an electric harvester piezoelectric transducer. Figure 1 shows the flow diagram of the proposed design of a piezoelectric instrumentation system for an electrical energy harvester. The proposed system is designed using Proteus software for modelling and simulation during the design stage.

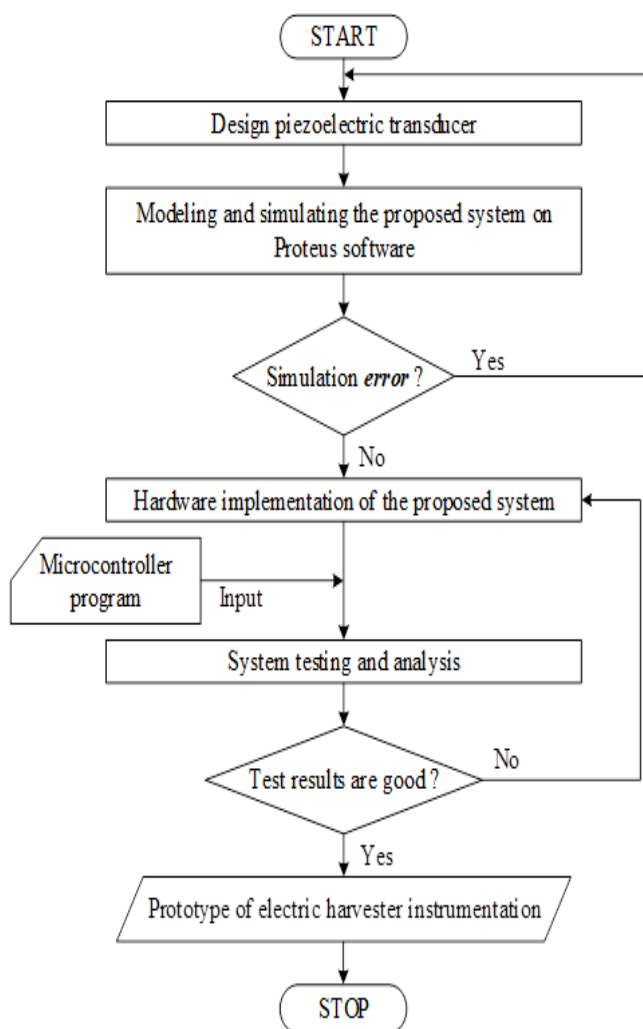

Figure 1. Flow diagram of the Proposed Instrumentation System Design

2.1. Hardware Instrumentation Design Implementation

Building a prototype piezoelectric sensor instrumentation system to convert rainfall into electrical energy involves integrating both hardware and software

components for effective communication and functionality. The hardware structure consists of a personal computer (PC) or laptop, a piezoelectric sensor measuring, jumper cables, a water pump, an Arduino Mega 2560, resistors, an IC LM741 Op Amp Chip, a printed circuit board (PCB), a Liquid crystal display (LCD) character (16x2), an SD card data logger, Keypad, and a tool frame. Figure 2 shows a schematic diagram of a piezoelectric-based rainfall power generation instrumentation system. The conceptual scheme for the piezoelectric-based rainfall power generation system model is presented in Figure 3. The piezoelectric rain power generation system model is designed to test the conceptual scheme for rain power generation. The stationary plate holds useful the water pumped by it, while a nozzle on it produces raindrops of the desired size. The water pump is useful for pumping water through a water hose to the stationary plate. The piezoelectric transducer can move the moving plate up and down, adjusting the distance between it and the stationary plate. The specified distances are 170 cm and 190 cm. This change in distance is useful for testing the effectiveness of the instrumentation system. The wheels are placed on the bottom of the frame to facilitate the movement of experimental equipment

Simulation of rainfall at different altitudes because rainfall can vary depending on the altitude of the location, for example mountainous areas or lowlands. At higher altitudes, rainfall is often lower or has different characteristics, which can affect the efficiency of energy collection. Therefore, taking the altitude factor into account can be relevant in the design of the system, but other aspects such as air pressure and wind must also be taken into account. The water pressure variable can affect the force received by the piezoelectric element and how energy is generated. This is because the piezoelectric element generates electrical energy when it experiences changes in pressure or mechanical tension. One important aspect that needs to be tested is whether altitude (related to water pressure) can affect the reliability of the piezoelectric instrument.

The wind variable can indeed affect the direction of the water fall, as in the case of rain or splashes of water from certain sources. However, if in the simulation the water is protected by a plastic shield, the influence of the wind on the direction of the water fall can be ignored, because the shield acts as a barrier that stabilizes the direction of the water flow and prevents the influence of external factors such as wind.

Rainfall will be visible in the voltage output at different elevations. The setup is designed to simulate rainfall at different heights to evaluate the repeatability and reproducibility of the instrumentation system. However, it does not account for other important variables such as water pressure and wind, which can affect measurement accuracy.

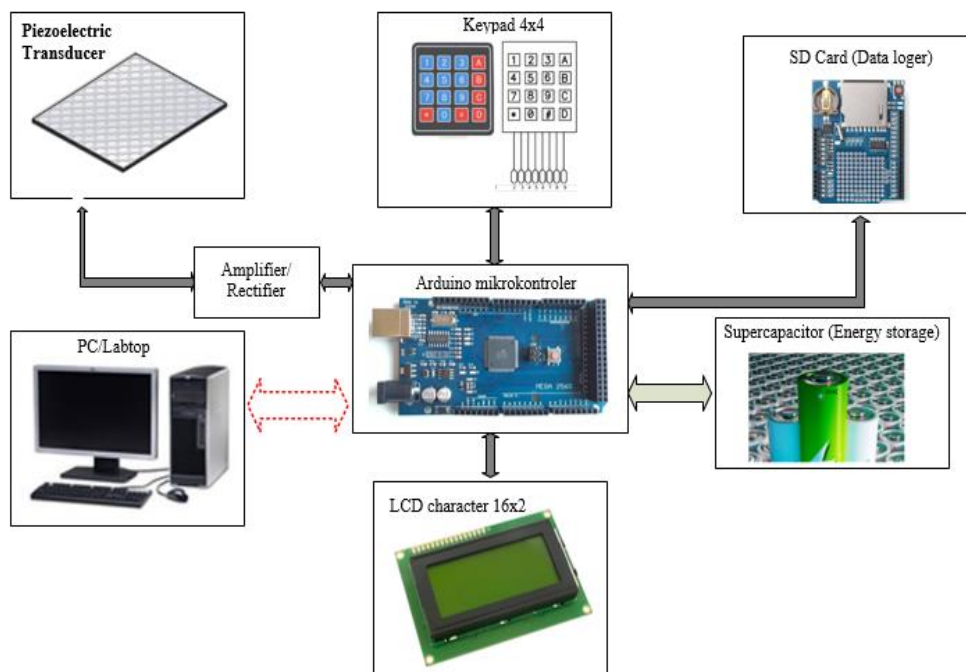

Figure 2. Schematic diagram of a piezoelectric-based rainfall power generation instrumentation system

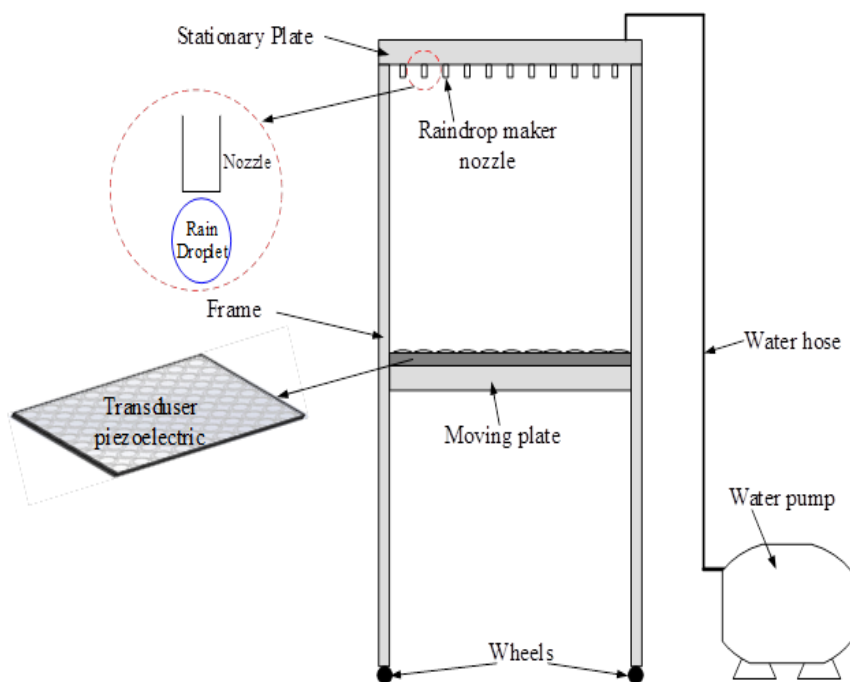

Figure 3. The conceptual scheme for the piezoelectric-based rainfall power generation system model

Rainfall-based power generation using piezoelectricity offers an innovative solution that can be applied at various scales. At the micro scale, this system can provide energy for daily needs at a low initial cost, although its efficiency is limited. At the medium and large scale, although the cost is higher and the efficiency is limited, this technology can contribute to a renewable energy system with a positive environmental impact. Overall, although piezoelectricity cannot yet replace primary energy sources, it has great potential to be a complement in reducing dependence on fossil fuels and helping to create more sustainable energy solutions.

The piezoelectric sensor will be the primary component that converts mechanical strain from rainfall into electrical energy. Arduino Mega2560 acts as the microcontroller to interface with the piezoelectric sensor, process data, control the water pump, and communicate with the PC or laptop. The IC LM741 Op Amp Chip is used for signal conditioning to amplify and filter the signals from the piezoelectric sensor. The printed circuit board (PCB) provides a platform to mount and interconnect the various components neatly and reliably. LCD characters (16x2) display relevant information such as sensor readings, system status, and any messages. SD Card Data Logger logs rainfall intensity energy

generated onto an SD card for later analysis. Jumper cables are useful for making electrical connections between different components on the breadboard, or PCB. Circuits use resistors for various purposes, such as voltage division or current limiting. The Arduino controls the water pump to simulate or manage the flow of water over the piezoelectric sensor. The tool frame provides a structure to mount and position the piezoelectric sensor and other components effectively in the testing environment.

2.1.1 Piezoelectric Transducer Design

This design uses a PZT (Lead Zirconate Titanate) type piezoelectric sensor. The disc is 10 mm in diameter and 1 mm thick. We use this sensor because of its strong piezoelectric properties. The design concept ensures that the piezoelectric transducer meets the specific requirements of the application. A square-shaped, laboratory-scale piezoelectric transducer with dimensions of 40 cm by 40 cm is used for designing an instrumentation system. Figure 4 shows the proposed piezoelectric transducer design. For the purpose of testing the effectiveness of the instrumentation system, transducers consisting of several piezoelectric sensor components will be connected in series and parallel.

2.1.2 Amplifier/Rectifier

A power amplifier, also called a power amplifier, is an electronic circuit that functions to strengthen or enlarge the input signal. In a piezoelectric sensor, the power amplifier will amplify the analog vibration signal from the vibration source into a larger signal. The intended vibration signal source can come from a piezoelectric transducer that can convert vibration

energy into an electrical signal. The electrical signal in the form of an AC signal is then amplified by the current (I) and voltage (V) so that it becomes a larger output. The amount of amplification is called gain. Gain, which is usually symbolized by G with units of decibels (dB), is the result of dividing the power in the output section (Pout) by the power in the input section (Pin) in the form of AC electrical frequencies.

The electrical signal produced by the input transducer is generally very small, around a few millivolts or even a few microvolts. Therefore, the electrical signal must be amplified in order to move or operate the output transducer device, such as a piezoelectric sensor. In a small signal amplifier, the main factors are linearity amplification and increasing the gain. Because of the small signal voltage and current, the amount of power handling capacity for power efficiency becomes important to consider. A power amplifier, or large signal amplifier, is a type of amplifier that provides enough power to be able to drive electrical devices.

2.1.3 Arduino Microcontroller

Figure 5 shows the pin configuration of the Arduino Mega2560 board. Each pin on this board has a specific function. All of the analog pins on this board can be used as digital I/O pins. This board enables you to design the Arduino Mega Projector. These boards provide a flexible work memory area and processing capacity, allowing them to work with a variety of sensors without delay. When compared to other types of Arduino boards, these have superior physical properties. A microcontroller is a chip-based, operational computer. The microcontroller contains an input-output device, memory, and a CPU.

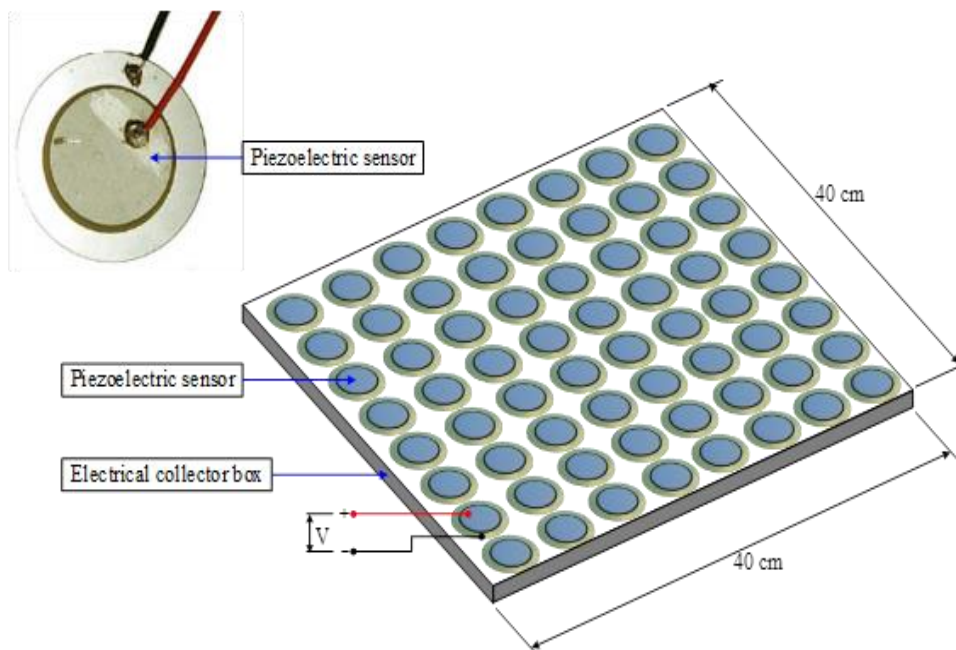

Figure 4. Proposed Piezoelectric Transducer Design

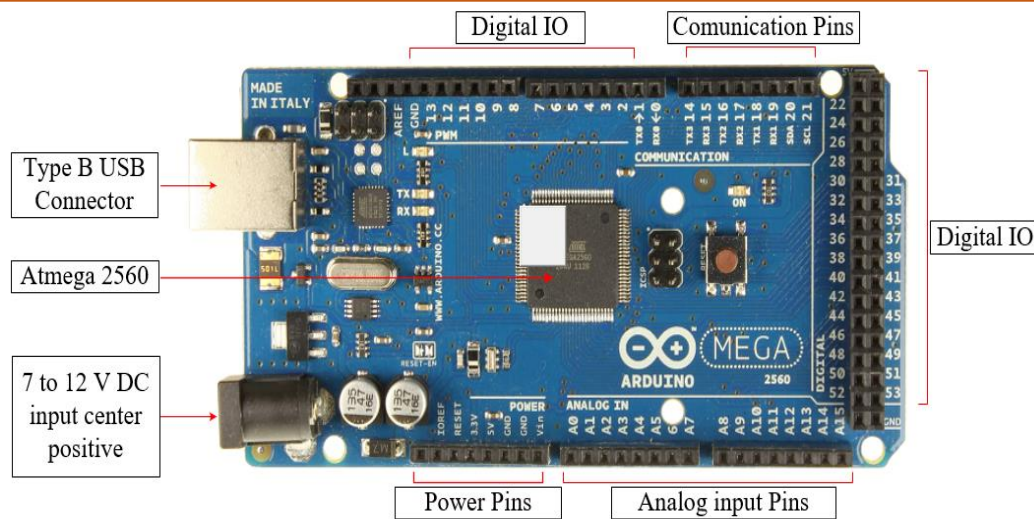

Figure 5. The Arduino Mega2560 pin configuration

To interface with external devices, the microcontroller uses memory to store programs or I/O device data. The use of microcontrollers in this study is electronic instrumentation. The type of microcontroller used is the Arduino Mega2560, which functions as an electronic controller to read and write data so that it can be connected to a computer. The Arduino Mega2560 is a microcontroller board built around the ATmega2560. The Arduino Mega2560 contains 54 digital input/output pins, 15 of which can be used as PWM outputs, 16 as analog inputs, and 4 as UART (hardware serial port). It also has a 16 MHz crystal oscillator, USB connection, power jack, ICSP header, and a reset button. Simply connect the microcontroller to a computer via a USB wire or power it with an AC-DC adapter or battery to get it started.

2.1.4 SD Card data logger

The Secure Digital Card (SD Card) is a non-volatile memory card commonly utilized in portable electronic devices, including data loggers. This study utilizes a data logger as a device to automatically capture data from piezoelectric transducer during operating time. Figure 6 shows the SD card data logger used to automatically record data from the piezoelectric transducer. The three key phases of using an SD card with an Arduino to record data from a piezoelectric sensor are reading the signal, processing the data, and saving it to the SD card. The following is a detailed explanation of this operational concept:

2.1.4.1 Hardware connections

Connect the other end of the piezoelectric sensor to ground (GND) and one end to an analog pin on the Arduino. For the SD Card Module, connect pins 12 and 11 as master slaves in and out (MISO and MOSI, respectively), pins 13 and 10 as serial clocks and chip select (SCK and CS, respectively), and pins VCC and GND.

2.1.4.2 Initialize the SD card and sensor

Use the Arduino, Serial Peripheral Interface (SPI), and SD libraries to initialize the SD card. Verify the correct installation of the SD card.

2.1.4.3 Read data from the sensor

Read the analog data from the piezoelectric sensor and save the value to a variable for further processing.

2.1.4.4 Save data to SD Card

Open a file on the SD card to write data. Make sure to close the file after the writing is complete.

2.1.4.5 Data Processing

Arduino transforms analog values into processable digital data. The acquired digital data is saved on the SD card for subsequent analysis or record-keeping. Before using the SD card, confirm that it is working and that files are closed correctly to prevent the corruption of data. Make sure there is enough storage on the SD card to accommodate the intended duration of data collection.

2.2 Software System Design

In order to process the data, harvest energy from the piezoelectric sensor, and use it, there are a few processes involved in designing Arduino software for piezoelectric energy harvesters. Figure 7 shows the flow diagram for designing Arduino software. The following explains how to develop Arduino software using piezoelectricity to generate electricity from rainfall: The first, initialize the Arduino and set up the pins to read sensor data. Initiate serial communication for debugging or monitoring data. Second, use analog inputs to read the voltage generated by the piezoelectric sensor.

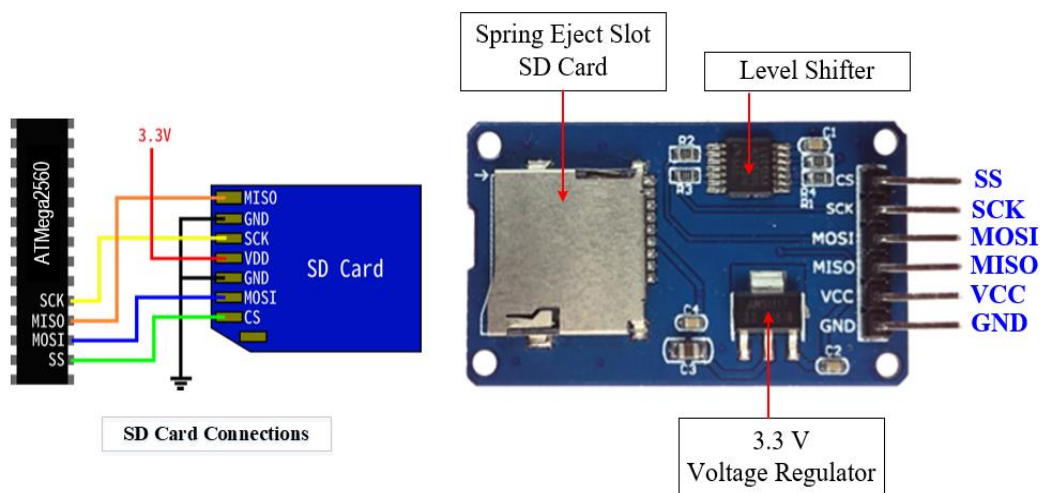

Figure 6. SD card data logger pinout

Previous to this, apply scaling and calibration to convert the raw readings into usable data. Third, implement routines to capture energy and store it in a capacitor or battery. Furthermore, monitor energy levels to determine when enough energy is available to power a load. Fourth, data processing entails smoothing or filtering the sensor measurements. The purpose of this stage is to compute the power or energy produced over time. Fifth, display the processed data on an LCD and log it to an SD card. Use serial communication to send the data to a computer or other device for analysis. Sixth, regulate the output by feeding a low-power LED or other modest load with the energy that has been captured. Use logic in this situation to control energy consumption, turning on and off the load in accordance with the energy at hand. Implement sleep mode or other power-saving features to maximize efficiency. Seventh, continuously monitor and adjust the system to optimize performance.

Data processing and data logging can help to solve problems like data loss and sensor interference. Both of these strategies assist in maintaining and correcting lost or corrupted data, as well as providing a more effective monitoring system. Data processing is concerned with processing and mending acquired data such that it is accurate and helpful for analysis. Meanwhile, the Data log functions to record all system events, such as sensor interference or errors, in real-time. This log is used for analysis of the cause of the problem, data recovery, notification, and report generation. These two systems work together to maintain data reliability and support proper decision making.

The software is a C++ program for a microcontroller with an Arduino compiler. C++ program will run on the Arduino Mega2560 and will handle tasks as follows:

- reading analogue signals from the piezoelectric sensor via the LM741 Op Amp,

- controlling the water pump based on sensor readings (simulating rainfall intensity),
- displaying relevant information on the LCD screen,
- logging data onto the SD card data logger, and
- Implementing any necessary algorithms for energy harvesting or system optimization.

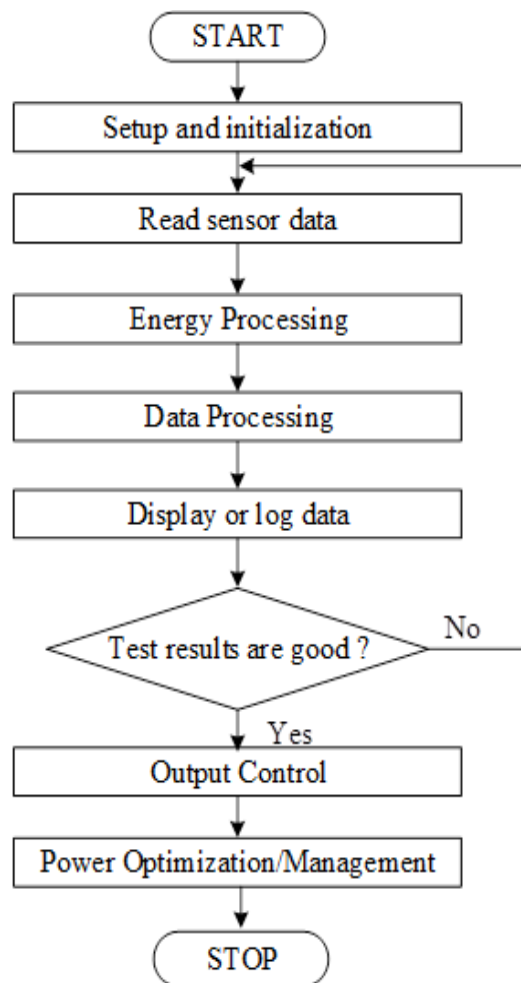

Figure 7. Flow diagram for designing Arduino software for piezoelectric energy harvesters

2.3. Repeatability and Reproducibility of Instrumentation Systems

Statistical analysis is used to test the Repeatability and Reproducibility of the instrument. Repeatability and Reproducibility are important parts of testing the quality and consistency of a process or measurement tool. Both of these concepts come from the Gage Repeatability and Reproducibility (Gage R&R) method, which is used in quality control to assess how well a measurement system is functioning. This analysis uses the Average and Range method. The relevant quantities are calculated as follows:

The measure of repeatability (or equipment variation), denoted by EV , is calculated as

$$EV = \bar{R} \times K_1 \quad (1)$$

where \bar{R} is the average range and $K = d/\nu_2$ is the adjustment factor. The quantity of d_2 depends on the number of parts used to calculate a single range.

The measure of reproducibility, denoted by AV , is calculated as

$$AV = \sqrt{(\bar{X}_{diff} \times K_1)^2 - \frac{(EV)^2}{nr}} \quad (2)$$

Where \bar{X}_{diff} is the difference between the maximum operator average and the minimum operator average, $K_2 = v/d_2^*$ is the adjustment factor, n is the number of parts, and r is the number of trials. Reproducibility is contaminated by gage error and is adjusted by subtracting $(EV)^2/nr$.

The measure of repeatability and reproducibility, denoted by R&R, is calculated as

$$R \& R = \sqrt{(EV)^2 + (AV)^2} \quad (3)$$

3. Results and Discussion

3.1. Instrumentation System Simulation in Proteus

Simulating an instrumentation system for piezoelectric electrical energy harvesting using Proteus can be an outstanding way to understand how the system works before its physical implementation. Proteus is a commonly used software for simulating electronic circuits, and although Proteus does not have built-in piezoelectric components, in the design process it is possible to create a close simulation using existing components.

After constructing the circuit for the electrical energy harvesting instrumentation system, Proteus

intelligent schematic input system (ISIS) simulates it. In this section, Proteus is used to automate electronic design processes. Simulation is used to optimize circuit parameters prior to the practical fabrication of the intended system. Each component is selected by selecting the component schematic from the Proteus toolbar library. Figure 8 shows the complete circuit schematic, which includes all critical components arranged in the workspace prior to circuit assembly. The simulation of the instrumentation system for piezoelectric power generation using Proteus produced positive results, thus this design was adopted in hardware manufacturing.

3.2. Hardware Implementation for Instrumentation System

We build the instrumentation system hardware using circuit diagrams created with Proteus. The hardware of the measurement instrumentation system consists of a piezoelectric sensor assembly, a signal conditioning and data processing unit with an LCD, an Arduino microcontroller interface, and data acquisition software on a laptop.

3.2.1. Implementation of piezoelectric transducer

A lead zirconate titanate PZT-type piezoelectric sensor was used in this study. This study employs two circuits for piezoelectric transducers: series circuits and parallel circuits. Piezoelectric transducers use multiple piezoelectric sensors in series or parallel configurations to assess the effectiveness of an instrumentation system. We connect 63 piezoelectric sensor components to ceramics to create the piezoelectric circuit. Figure 9 and Figure 10 show the implementation of the series and parallel configurations, respectively.

To achieve the best performance and device safety, carefully arrange the assembly of 63 piezoelectric sensor chips in series or parallel. In a series configuration, the piezoelectric sensors connect in series. This means that all the positive terminals of one sensor are connected to the negative terminal of the next sensor, and so on. This configuration increases the total output voltage of the transducer. If each piezoelectric sensor produces a certain voltage, the total voltage produced is the sum of the voltages of each sensor. However, a single piezoelectric sensor limits the current production. In addition, all sensors must experience the same force or pressure to obtain optimal results. In a parallel configuration, the piezoelectric sensors connect in parallel to the same terminals. The configuration of connecting the positive and negative terminals of all sensors increases the total output current of the transducers. The total current produced is the sum of the currents from each sensor. It also allows for load sharing, which can increase resistance to damage.

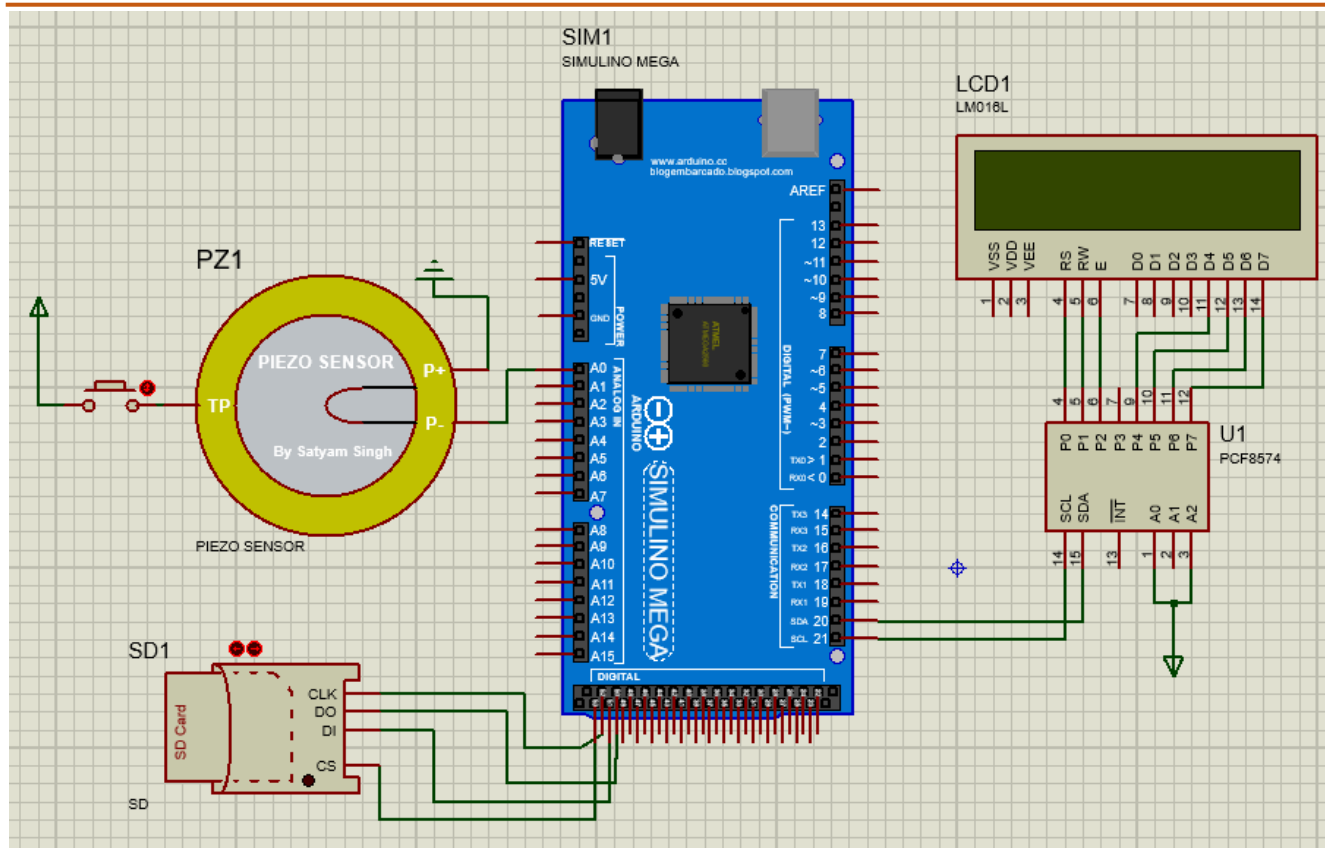

Figure 8. Instrumentation system circuit in Proteus.



Figure 9. Series circuit of piezoelectric transducer

Nevertheless, the voltage of a single piezoelectric sensor will be equivalent to the entire output voltage. The consistency with which each sensor responds to force or pressure has a substantial impact on the performance of an entire system.

3.2.2. Signal conditioning for piezoelectric transducer

Piezoelectric sensors produce signals in the form of voltage or current when subjected to mechanical pressure or vibration. However, piezoelectric sensors



Figure 10. Parallel circuit of piezoelectric transducer

often produce weak signals that need conditioning for proper use in electronic applications. The weak signal of piezoelectric sensor needs amplification to increase its amplitude, making it easier for the electronic system to process the amplified signal. For this application, it is very appropriate to use the LM741 as an op-amp based amplifier. The LM741 is a widely used operational amplifier (op-amp) in various electrical applications. As an op-amp, LM741 can be used in a variety of amplifier designs. In instrumentation amplifier circuits, we use the LM741 to measure small signals that are exposed to

noise. Figure 11 shows the pinout diagram for the LM741. It typically comes in an 8-pin dual-in-line package (DIP). A standard op-amp schematic diagram can represent the LM741 operational amplifier (op-amp). This schematic shows the internal configuration of the op-amp, including the various functional blocks. Figure 12 shows a simplified version of the internal schematic for the LM741. To eliminate noise or unwanted frequency components from the signal, a passive filter (resistor, capacitor) or an active filter (op-amp with passive components) is needed to filter out high- or low-frequency noise. Band-pass filters target certain relevant frequencies. In this arrangement, the piezoelectric sensor signals can be processed effectively for power generation applications. Figure 13 shows the implementation of signal conditioning for a piezoelectric transducer.

3.2.3 Prototype Instrumentation System for Piezoelectric Transducer

Figure 14 shows a prototype instrumentation system for generating electricity from rainfall based on piezoelectric transducer. The piezoelectric transducer is placed on the open surface exposed to rain. We use lead zirconate titanate (PZT), a sensitive and efficient piezoelectric material. A charge amplifier and a voltage amplifier convert a high impedance piezoelectric signal into a steady voltage signal for further processing. The voltage amplifier raises the signal amplitude to a suitable-level for use as an electrical energy source. We can store energy from rain using batteries or supercapacitors for later use when rain intensity is low or absent.

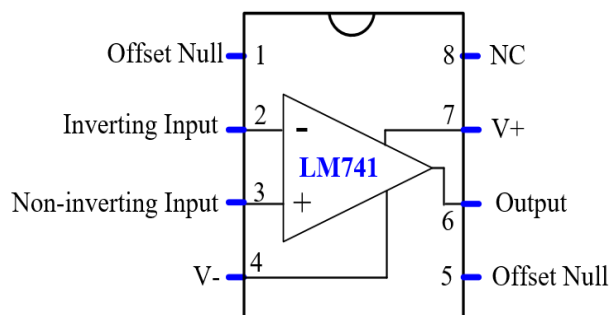

Figure 11. LM741 pinout diagram

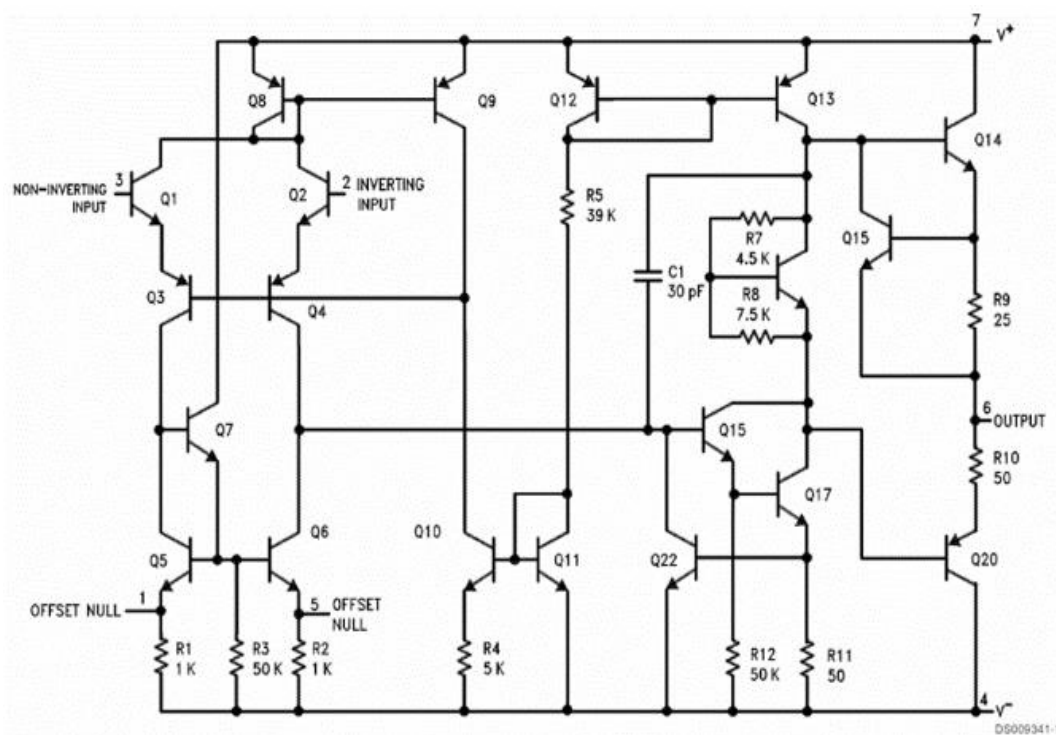

Figure 12. LM741 IC schematic diagram

Amplifier circuit

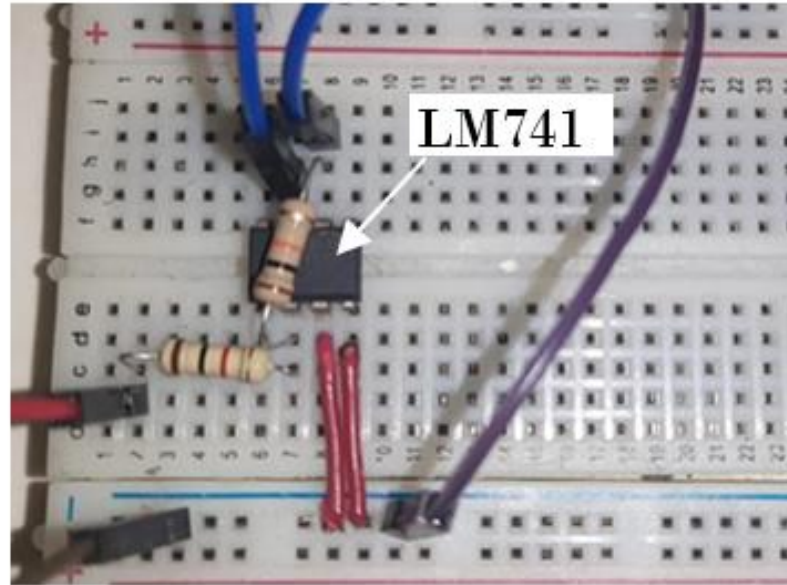

Figure 13. Implementation of signal conditioning for piezoelectric transducer

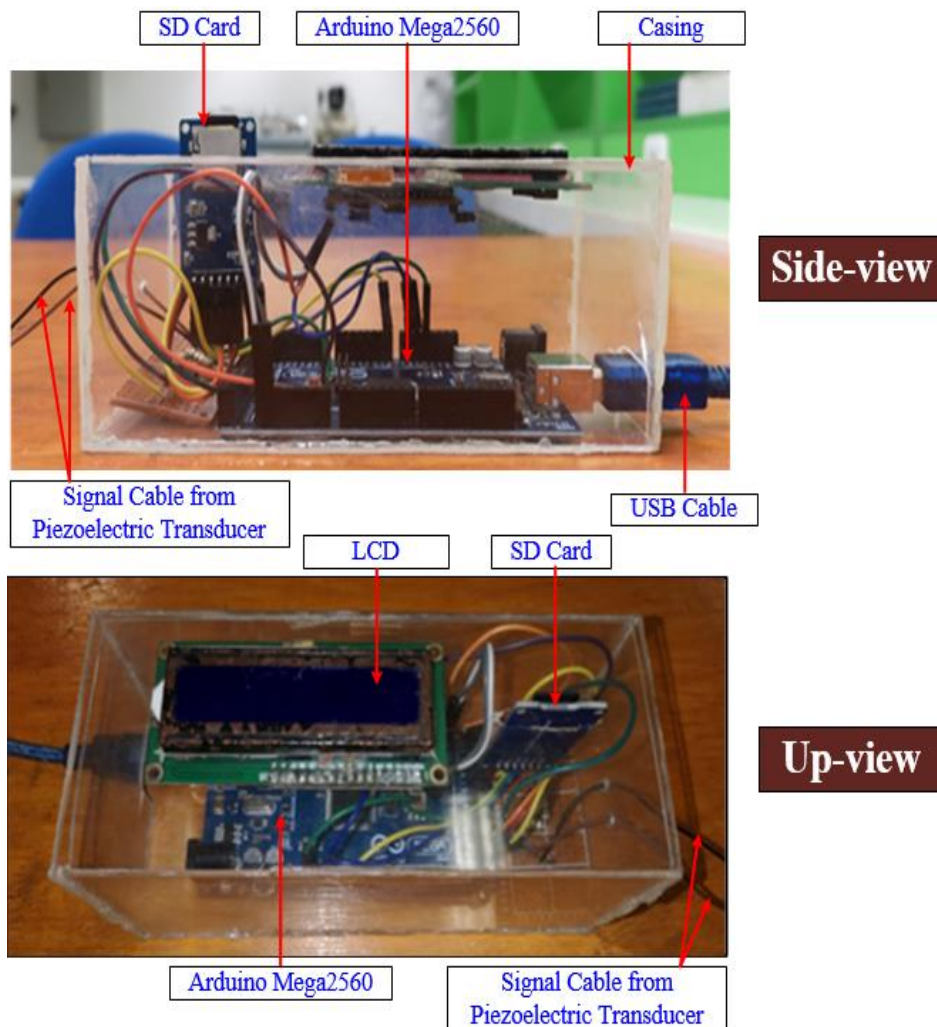

Figure 14. Prototype instrumentation system for piezoelectric transducer

The data acquisition system used is the Arduino Mega2560 microcontroller, which functions to process data from the piezoelectric sensor and control the energy storage process data and monitoring. The

system monitors real-time LCD display of energy production, energy storage status, and general operational conditions.

3.3. Hardware System Test

The purpose of this test is to analyze reliability of the system and ensure that it was deployed as planned. Separate tests were conducted first, followed by tests on the integrated system. LCD testing is carried out to confirm that the programming language and the circuit connected to the LCD are in working order. The Arduino software provides a comprehensive library, including an example for testing the LCD. Prior to conducting the LCD test, the LCD needs to be connected to the Arduino Mega board. Then, in the Arduino software, the type of board to be used can be selected by clicking on Tools-Board-Arduino Mega for the LCD test. The SD card test is used to determine whether the programming language and connectivity are correct and working properly. Before testing the SD card, the first step is to attach it to the Arduino Mega board via the pin position circuit.

The piezoelectric transducer was tested to determine its ability to generate voltage. During testing, the sensor was pressed and the voltage results were recorded using an LCD and serial monitor. Before testing the piezoelectric sensor, it must be assembled with the Arduino Mega 2560 board. The sensor produced varying readings based on the amount of pressure applied. Quick pressure resulted in higher voltage, while slower pressure resulted in lower voltage. After testing the amplifier to determine if the voltage current from the piezoelectric sensor could be amplified to produce a larger voltage output, the final stage of hardware system testing involves testing the entire circuit. This extensive testing attempts to confirm that all previously built circuits and programs are synced and running properly. It also checks to see if the input devices from the piezoelectric sensors can work together to produce accurate voltage output, if the measurement values from these piezoelectric sensors can be correctly displayed on the LCD and serial monitor, and if the SD Card used can accurately store the data from these tests.

3.4. Experimental Results for Power Plant Instrumentation System

The power plant instrumentation system was experimentally tested with simulated rainwater sprayed from a nozzle located at the bottom of reservoir. Water was used to generate pressure, and data was taken at six different measurement heights: 170 cm, 190 cm, 210 cm, 230 cm, 250 cm, and 270 cm, with a 20 centimeters variation between each height. Measurements were taken from the water reservoir above the piezoelectric sensor array, and each height variation was recorded for

5 minutes. Figure 15 represents the experimental setup, and Figure 16 depicts the actual experiment.

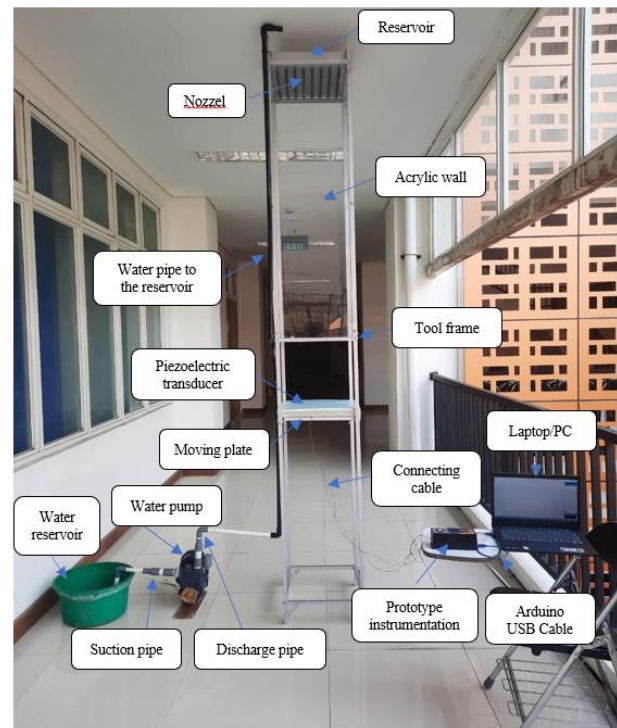

Figure 15. Experimental setup for data collection



Figure 16. Actual experiment

The data collecting process for evaluating this instrumentation equipment begins by preparing water in a storage container. After collecting the water, it will be poured into a tank installed above the experimental device. The water in the tank will then fall onto a base built over a network of piezoelectric sensors. This base is built so that water does not fall directly onto the sensor array, but rather on the platform that has been created. The falling water causes pressure and vibrations, which trigger the piezoelectric sensors and generate electrical voltage (volts). Once the sensors generate voltage, it

enters the amplifier circuit designed to boost the voltage. The Arduino Mega will then read the voltage from the amplifier and convert it to digital data, which will be displayed on the computer's LCD and serial monitor. This data will then be stored on an SD card and used for research purposes.

When evaluating the instrumentation system, the sensor circuit on the piezoelectric transducer employs two types of circuits: parallel and series. The study investigates changes in height (cm) and time (minutes). The instrumentation system testing results for series and parallel circuits, as well as height variations, are shown above.

3.4.1. Testing on a series of piezoelectric transducer

Throughout this series, each experiment will use six distinct heights: 170 cm, 190 cm, 210 cm, 230 cm,

250 cm, and 270 cm. Each height will be tested for a total of five minutes. Table 1 shows the average value of ten trials completed during series circuit testing.

The experimental results in Table 1 show that the voltage output of the piezoelectric material is not constant. This fluctuation is driven by variables such as inconsistent water pressure against the sensor barrier and unpredictable wind, which prevent the falling water from reaching its full capacity. Throughout each trial, the generated voltage fluctuated, with voltage results rising and declining with height changes.

The voltage (Volt), in 6 different heights of falling rain drops have been measured by 3 operators, using the same measurement equipment. Each operator measures each height ten times, and the experimental data is given in Table 1.

Table 1. Experimental data on series circuits.

Operator	Height (cm)	Trials									
		1	2	3	4	5	6	7	8	9	10
		Voltage (V)									
A	170	2.45	2.42	2.43	2.41	2.38	2.39	2.41	2.4	2.37	2.39
	190	2.31	2.27	2.32	2.33	2.4	2.41	2.37	2.37	2.44	2.48
	210	2.25	2.22	2.29	2.29	2.35	2.29	2.39	2.41	2.4	2.36
	230	2.34	2.36	2.38	2.37	2.36	2.33	2.3	2.3	2.29	2.2
	250	2.57	2.65	2.67	2.64	2.64	2.64	2.68	2.64	2.63	2.65
	270	2.64	2.63	2.62	2.63	2.64	2.65	2.63	2.65	2.64	2.65
B	170	2.25	2.21	2.23	2.21	2.24	2.47	2.21	2.31	2.19	2.19
	190	2.35	2.28	2.38	2.32	2.39	2.4	2.35	2.34	2.42	2.47
	210	2.35	2.21	2.21	2.23	2.38	2.21	2.38	2.39	2.29	2.35
	230	2.34	2.36	2.32	2.37	2.36	2.33	2.3	2.3	2.29	2.2
	250	2.56	2.61	2.61	2.62	2.62	2.61	2.62	2.64	2.63	2.62
	270	2.61	2.63	2.62	2.62	2.64	2.64	2.63	2.61	2.62	2.65
C	170	2.44	2.42	2.41	2.41	2.38	2.39	2.41	2.4	2.38	2.39
	190	2.31	2.33	2.32	2.34	2.4	2.39	2.37	2.37	2.44	2.48
	210	2.23	2.23	2.29	2.29	2.35	2.29	2.39	2.41	2.4	2.36
	230	2.33	2.35	2.35	2.36	2.36	2.34	2.31	2.32	2.29	2.25
	250	2.56	2.67	2.66	2.63	2.64	2.64	2.67	2.64	2.64	2.62
	270	2.63	2.62	2.62	2.61	2.63	2.62	2.64	2.65	2.64	2.65

Table 2. Average range for all operators and all heights series circuits.

Operator	Height (cm)	Trials										Range	Mean	Mean Range	Mean of Mean
		1	2	3	4	5	6	7	8	9	10				
		Voltage (V)													
A	170	2.45	2.42	2.43	2.41	2.38	2.39	2.41	2.4	2.37	2.39	0.08	2.405	0.133	2.450
	190	2.31	2.27	2.32	2.33	2.4	2.41	2.37	2.37	2.44	2.48	0.21	2.370		
	210	2.25	2.22	2.29	2.29	2.35	2.29	2.39	2.41	2.4	2.36	0.19	2.325		
	230	2.34	2.36	2.38	2.37	2.36	2.33	2.3	2.3	2.29	2.2	0.18	2.323		
	250	2.57	2.65	2.67	2.64	2.64	2.64	2.68	2.64	2.63	2.65	0.11	2.641		
	270	2.64	2.63	2.62	2.63	2.64	2.65	2.63	2.65	2.64	2.65	0.03	2.638		
B	170	2.25	2.21	2.23	2.21	2.24	2.47	2.21	2.31	2.19	2.19	0.28	2.251	0.157	2.413
	190	2.35	2.28	2.38	2.32	2.39	2.4	2.35	2.34	2.42	2.47	0.19	2.370		
	210	2.35	2.21	2.21	2.23	2.38	2.21	2.38	2.39	2.29	2.35	0.18	2.300		
	230	2.34	2.36	2.32	2.37	2.36	2.33	2.3	2.3	2.29	2.2	0.17	2.317		
	250	2.56	2.61	2.61	2.62	2.62	2.61	2.62	2.64	2.63	2.62	0.08	2.614		
	270	2.61	2.63	2.62	2.62	2.64	2.64	2.63	2.61	2.62	2.65	0.04	2.627		
C	170	2.44	2.42	2.41	2.41	2.38	2.39	2.41	2.4	2.38	2.39	0.06	2.403	0.112	2.449
	190	2.31	2.33	2.32	2.34	2.4	2.39	2.37	2.37	2.44	2.48	0.17	2.375		
	210	2.23	2.23	2.29	2.29	2.35	2.29	2.39	2.41	2.4	2.36	0.18	2.324		
	230	2.33	2.35	2.35	2.36	2.36	2.34	2.31	2.32	2.29	2.25	0.11	2.326		
	250	2.56	2.67	2.66	2.63	2.64	2.64	2.67	2.64	2.64	2.62	0.11	2.637		
	270	2.63	2.62	2.62	2.61	2.63	2.62	2.64	2.65	2.64	2.65	0.04	2.631		
Total mean range												0.1342			
Range of means													0.0362		

Table 3. The d_2^* and d_2 values for the mean range distribution [21]

d_2^*	Size of samples									
Samples	2	3	4	5	6	7	8	9	10	
1	1.414	1.912	2.239	2.481	2.673	2.830	2.963	3.078	3.179	
2	1.279	1.805	2.151	2.405	2.604	2.768	2.906	3.025	3.129	
3	1.231	1.769	2.120	2.379	2.581	2.747	2.886	3.006	3.112	
4	1.206	1.750	2.105	2.366	2.570	2.736	2.877	2.997	3.103	
5	1.191	1.739	2.096	2.358	2.563	2.730	2.871	2.992	3.098	
6	1.181	1.731	2.090	2.353	2.558	2.726	2.867	2.988	3.095	
7	1.173	1.726	2.085	2.349	2.555	2.723	2.864	2.986	3.092	
8	1.168	1.721	2.082	2.346	2.552	2.720	2.862	2.984	3.090	
9	1.164	1.718	2.080	2.344	2.550	2.719	2.860	2.982	3.089	
10	1.160	1.716	2.077	2.342	2.549	2.717	2.859	2.981	3.088	
11	1.157	1.714	2.076	2.340	2.547	2.716	2.858	2.980	3.087	
12	1.155	1.712	2.074	2.339	2.546	2.715	2.857	2.979	3.086	
13	1.153	1.710	2.073	2.338	2.545	2.714	2.856	2.978	3.085	
14	1.151	1.709	2.072	2.337	2.545	2.714	2.856	2.978	3.085	
15	1.150	1.708	2.071	2.337	2.544	2.713	2.855	2.977	3.084	
d_2										
> 15	1.128	1.693	2.059	2.326	2.534	2.704	2.847	2.970	3.078	

Table 4. Criteria for evaluating measuring systems using %GRR.

<10%:	It is considered to be an acceptable measurement system.
>=10% & <=30%:	It may be acceptable depending on application and cost factor, but try to improve it.
>30%:	It's considered to be unacceptable and should be improved.

Table 5. Experimental data on parallel circuits.

Operator	Height (cm)	Trials									
		1	2	3	4	5	6	7	8	9	10
		Voltage (V)									
A	170	2.03	2.05	2.02	2.05	2.04	2.04	2.06	2.05	2.03	2.05
	190	2.1	2.25	2.26	2.26	2.22	2.19	2.19	2.27	2.17	2.11
	210	2.33	2.39	2.39	2.35	2.32	2.31	2.29	2.18	2.13	2.15
	230	2.35	2.39	2.44	2.41	2.35	2.52	2.45	2.53	2.48	2.51
	250	2.13	2.21	2.37	2.24	2.19	2.3	2.32	2.24	2.21	2.14
	270	2.21	2.24	2.32	2.51	2.64	2.65	2.64	2.66	2.65	2.65
B	170	2.04	2.04	2.03	2.05	2.05	2.04	2.03	2.05	2.05	2.05
	190	2.11	2.21	2.2	2.16	2.21	2.19	2.19	2.23	2.17	2.21
	210	2.33	2.39	2.39	2.35	2.32	2.31	2.29	2.18	2.13	2.15
	230	2.34	2.36	2.32	2.37	2.36	2.33	2.3	2.3	2.29	2.2
	250	2.21	2.24	2.32	2.51	2.64	2.65	2.64	2.66	2.65	2.65
	270	2.61	2.63	2.62	2.62	2.64	2.3	2.32	2.24	2.21	2.14
C	170	2.3	2.32	2.24	2.21	2.14	2.31	2.29	2.18	2.13	2.15
	190	2.3	2.32	2.24	2.21	2.14	2.39	2.37	2.37	2.44	2.48
	210	2.44	2.41	2.35	2.52	2.45	2.29	2.39	2.41	2.4	2.36
	230	2.33	2.39	2.39	2.35	2.32	2.3	2.32	2.24	2.21	2.14
	250	2.56	2.67	2.66	2.63	2.44	2.41	2.35	2.52	2.45	2.62
	270	2.33	2.39	2.39	2.35	2.32	2.31	2.29	2.18	2.13	2.15

Statistical analysis to test Repeatability and Reproducibility in parallel circuits as follows

Table 6. Average range for all operators and all heights parallel circuits.

Operator	Height (cm)	Trials										Range	Mean	Mean Range	Mean of Mean
		1	2	3	4	5	6	7	8	9	10				
		Voltage (V)													
A	170	2.03	2.05	2.02	2.05	2.04	2.04	2.06	2.05	2.03	2.05	0.04	2.042	0.223	2.287
	190	2.1	2.25	2.26	2.26	2.22	2.19	2.19	2.27	2.17	2.11	0.17	2.202		
	210	2.33	2.39	2.39	2.35	2.32	2.31	2.29	2.18	2.13	2.15	0.26	2.284		
	230	2.35	2.39	2.44	2.41	2.35	2.52	2.45	2.53	2.48	2.51	0.18	2.443		
	250	2.13	2.21	2.37	2.24	2.19	2.3	2.32	2.24	2.21	2.14	0.24	2.235		
	270	2.21	2.24	2.32	2.51	2.64	2.65	2.64	2.66	2.65	2.65	0.45	2.517		
B	170	2.04	2.04	2.03	2.05	2.05	2.04	2.03	2.05	2.05	2.05	0.02	2.043	0.253	2.297
	190	2.11	2.21	2.2	2.16	2.21	2.19	2.19	2.23	2.17	2.21	0.12	2.188		
	210	2.33	2.39	2.39	2.35	2.32	2.31	2.29	2.18	2.13	2.15	0.26	2.284		
	230	2.34	2.36	2.32	2.37	2.36	2.33	2.3	2.3	2.29	2.2	0.17	2.317		

Table 6. Average range for all operators and all heights parallel circuits.

Operator	Height (cm)	Trials										Range	Mean	Mean Range	Mean of Mean
		1	2	3	4	5	6	7	8	9	10				
		Voltage (V)													
	250	2.21	2.24	2.32	2.51	2.64	2.65	2.64	2.66	2.65	2.65	0.45	2.517		
	270	2.61	2.63	2.62	2.62	2.64	2.3	2.32	2.24	2.21	2.14	0.5	2.433		
C	170	2.3	2.32	2.24	2.21	2.14	2.31	2.29	2.18	2.13	2.15	0.19	2.227	0.265	2.345
	190	2.3	2.32	2.24	2.21	2.14	2.39	2.37	2.37	2.44	2.48	0.34	2.326		
	210	2.44	2.41	2.35	2.52	2.45	2.29	2.39	2.41	2.4	2.36	0.23	2.402		
	230	2.33	2.39	2.39	2.35	2.32	2.3	2.32	2.24	2.21	2.14	0.25	2.299		
	250	2.56	2.67	2.66	2.63	2.44	2.41	2.35	2.52	2.45	2.62	0.32	2.531		
	270	2.33	2.39	2.39	2.35	2.32	2.31	2.29	2.18	2.13	2.15	0.26	2.284		
												Total mean range		0.259	
												Range of means			0.048

Repeatability is calculated using the average range for all operators and all heights. For operator A and height 170 cm, the range is 0,08. For operator A and height 170 cm, the mean is 2,405. Similarly, compute the range and mean for each height. Next, calculate the average and range for each operator. For operator A, the mean of the range is 0.133. Additionally, the mean of operator A is 2,450. Similarly, compute the mean of the range and the mean of each operator. These data are given in Table 2.

From Table 2, The average of ranges, \bar{R} , is 0,1342. The d_2 values for the mean range distribution are shown in Table 3. From Table 3, with $n=18$ (the number of combinations of 6 heights multiplied by 3 operators) and the number of trials $r=10$, d_2 is 3,078. The constant $K_1=1/d_2=0,324$, then the repeatability is

$$EV = \bar{R} \times K_1 = 0.0436$$

\bar{X}_{diff} is 0,01427. From Table 3, with $n=6$ and $r=10$, d_2^* is 2,534. The adjustment factor K_2 is 0,394. Then the reproducibility is

$$AV = \sqrt{(\bar{X}_{diff} \times K_2)^2 - \frac{(EV)^2}{nr}} = 0.000000039$$

Repeatability and reproducibility are obtained as follows:

$$R \& R = \sqrt{(EV)^2 + (AV)^2} = 0.0436 = 4.36\%$$

Next, evaluate the outcomes. The Automotive Industry Action Group (AIAG) has provided the criteria for evaluating measuring systems using %GRR as shown in Table 5.

Based on Table 4, the Gage Repeatability and Reproducibility (Gage R&R) method is widely used in quality control to assess the precision of a measurement system. A result below 10% indicates that the system's variation is minimal and acceptable.

From Table 6, The average of ranges, \bar{R} , is 0,259. The d_2 values for the mean range distribution are shown in Table 4. From Table 4, with $n=18$ (the number of combinations of 6 heights multiplied by 3 operators) and the number of trials $r=10$, d_2 is 3,078. The constant $K_1=1/d_2=0,000324$, then the repeatability is

$$EV = \bar{R} \times K_1 = 0.00008$$

\bar{X}_{diff} is 0,0478. From Table 3, with $n=6$ and $r=10$, d_2^* is 2,534. The adjustment factor K_2 is 0,394. Then the reproducibility is

$$AV = \sqrt{(\bar{X}_{diff} \times K_2)^2 - \frac{(EV)^2}{nr}} = 0.01887$$

Repeatability and reproducibility are obtained as follows:

$$R \& R = \sqrt{(EV)^2 + (AV)^2} = 0.0189 = 1.89\%$$

Based on Table 5, since Gage R&R is 1.89%, it is in the green zone. Therefore, it is considered as an acceptable measurement system based on application and cost factors.

The maximum voltage recorded is only about 2.68 V and is considered inadequate for practical use but this voltage can be increased with a voltage booster before being processed by the voltage controller. Voltage boosters, or boost converters, have a minimum voltage limit in order to function properly. In general,

most voltage boosters are designed to accept inputs lower than the desired output voltage, but they require sufficient input voltage to start the conversion and voltage amplification process. Since 2.68 V is greater than 2 V, the input for this voltage booster meets the requirements.

4. Conclusions

This study successfully developed and tested a prototype instrumentation system for generating power from rain using piezoelectric transducers. The system, which incorporates PZT piezoelectric materials, an amplifier, and an Arduino Mega2560 microcontroller, demonstrated its ability to convert rain energy into electrical power. The staged testing process ensured the proper functionality of individual components, leading to an integrated system capable of generating measurable voltage.

Experimental results indicated that the output voltage varied depending on water pressure and external factors such as wind. The highest recorded voltage in a series circuit was 2.68V at a height of 250 cm, while in a parallel circuit, it reached 2.66V at 270 cm. These variations highlight the impact of environmental conditions on power generation efficiency.

In comparing the voltage output for series and parallel configurations, we can see the basic difference between the two configurations. In a series configuration, the total voltage is the sum of the voltages across each element in the circuit. In a parallel configuration, the voltage across all elements is the same.

Based on the statistical analysis of the experimental data for both series and parallel circuits in the power plant instrumentation system, the measurement system demonstrates a high level of precision and reliability. The calculated Gage Repeatability and Reproducibility (Gage R&R) value of 4.36% falls well below the 10% threshold established by the Automotive Industry Action Group (AIAG), indicating that the system is within the acceptable range for measurement variation. This confirms that the variations observed are primarily due to the measured process itself rather than inconsistencies in the measurement system. Consequently, the measurement system is considered valid and dependable for assessing voltage across different circuit configurations and operator performances, with no significant need for improvement at this time.

Future work will focus on finding better piezoelectric materials with higher energy conversion efficiency, exploring improved energy storage options like supercapacitors or advanced batteries, and designing smarter circuits to boost voltage and reduce energy loss. Integrating the system with other renewable sources such as solar or wind could provide a more

stable power supply. Real-world testing in different weather conditions will help evaluate performance, while studying large-scale applications on rooftops, roads, or buildings will show practical use. Finally, adding IoT-based monitoring can automate performance tracking and improve overall system efficiency.

References

- [1] N.E. DuToit, B.L. Wardle, S.G. Kim, Design considerations for MEMS-scale piezoelectric mechanical vibration energy harvesters. *Integrated Ferroelectrics*, 71(1), (2005) 121-160. <https://doi.org/10.1080/10584580590964574>
- [2] R. Guigon, J.J. Chaillout, T. Jager, G. Despesse, Harvesting raindrop energy: Theory. *Smart materials and structures*, 17(1), (2008) 015038. <https://doi.org/10.1088/0964-1726/17/01/015038>
- [3] R. Guigon, J.J. Chaillout, T. Jager, and G. Despesse, Harvesting raindrop energy: Experimental study. *Smart materials and structures*, 17(1), (2008) 015039. <https://doi.org/10.1088/0964-1726/17/01/015039>
- [4] C.H. Wong, Z. Dahari, M.H. Jumali, K. Mohamed, J.J. Mohamed, Simulation and Fabrication of Wagon-Wheel-Shaped Piezoelectric Transducer for Raindrop Energy Harvesting Application. *Journal of Electronic Materials*, 46, (2017) 1587-1597. <https://doi.org/10.1007/s11664-016-5201-2>
- [5] F. Viola, P. Romano, R. Miceli, G. Acciari, C. Spataro, (2014) Piezoelectric model of rainfall energy harvester, in 2014 9th International Conference on Ecological Vehicles and Renewable Energies, EVER, IEEE, Carlo, Monaco. <https://doi.org/10.1109/EVER.2014.6844093>
- [6] M. Al Ahmad, Piezoelectric water drop energy harvesting. *Journal of electronic materials*, 43, (2014) 452-458. <https://doi.org/10.1007/s11664-013-2826-2>
- [7] C. Covaci, A. Gontean, Piezoelectric energy harvesting solutions: A review. *Sensors*, 20(12), (2020) 3512. <https://doi.org/10.3390/s20123512>
- [8] M. Zhang, J. Wang, Experimental study on piezoelectric energy harvesting from vortex-induced vibrations and wake-induced vibrations. *Journal of Sensors*, 2016(1), (2016) 2673292. <https://doi.org/10.1155/2016/2673292>
- [9] W. Tian, Z. Ling, W. Yu, J. Shi, A review of MEMS scale piezoelectric energy harvester. *Applied Sciences*, 8(4), (2018) 645. <https://doi.org/10.3390/app8040645>
- [10] D. Kumar, P. Chaturvedi, N. Jejurikar, 2014 Piezoelectric energy harvester design and power

- conditioning, in 2014 IEEE Students' Conference on Electrical, Electronics and Computer Science, IEEE, Bhopal, India.
<https://doi.org/10.1109/SCEECs.2014.6804491>
- [11] D. Vasic, Y. Yao, PWM interface for piezoelectric energy harvesting. *Electronics Letters*, 49(13), (2013) 843-845.
<https://doi.org/10.1049/el.2013.1278>
- [12] J. Hu, J. Jong, C. Zhao, Vibration Energy Harvesting Based on Integrated Piezoelectric Components Operating in Different Modes, *IEEE Transactions on Ultrasonic, Ferroelectrics and Frequency Control*, IEEE, 57(2), (2010) 386-394.
<https://doi.org/10.1109/TUFFC.2010.1418>
- [13] X. He, Q. Wen, Y. Sun, Z. Wen, A low-frequency piezoelectric-electromagnetic-triboelectric hybrid broadband vibration energy harvester. *Nano Energy*, 40, (2017) 300-307.
<https://doi.org/10.1016/j.nanoen.2017.08.024>
- [14] Z. Yang, S. Zhou, J. Zu, D. Inman, High-Performance Piezoelectric Energy Harvesters and Their Applications. *Joule*, 2(4), (2018) 642-697.
<https://doi.org/10.1016/j.joule.2018.03.011>
- [15] A. Moonik, J. Rantung, B. Maluegha, Pemanen Energi Listrik Dari Curah Hujan Melalui Transduser Piezoelektrik Secara Seri Dan Paralel. *Jurnal Poros Mesin Unsrat*, 12(1), (2022) 1-12.
- [16] C.H. Wong, Z. Dahari, A. Abd Manaf, M.A. Miskam, Harvesting raindrop energy with piezoelectrics: A review. *Journal of Electronic Materials*, 44(1), (2015) 13-21.
<https://doi.org/10.1007/s11664-014-3443-4>
- [17] F. Narita, M. Fox, A Review on Piezoelectric, Magnetostrictive, and Magnetoelectric Materials and Device Technologies for Energy Harvesting Applications. *Advanced Engineering Materials*, 20(5), (2018) 1700743.
<https://doi.org/10.1002/adem.201700743>
- [18] M. Bichurin, R. Petrov, V. Leontiev, G. Semenov, O. Sokolov, Magnetoelectric Current Sensors. *Sensors*, 17(6), (2017) 1271.
<https://doi.org/10.3390/s17061271>
- [19] A.K. Batra, J.R. Currie, A.A. Alomari, M.D. Aggarwal, C.R. Bowen, A versatile and fully instrumented test station for piezoelectric energy harvesters. *Measurement*, 114, (2018) 9-15.
<https://doi.org/10.1016/j.measurement.2017.08.038>
- [20] Z. Wang, L. He, X. Gu, S. Yang, S. Wang, P. Wang, G. Cheng, Rotational energy harvesting systems using piezoelectric materials: A review. *Review of Scientific Instruments*, 92(4), 2021.
<https://doi.org/10.1063/5.0039730>
- [21] L.N. Harris, *Quality control and industrial statistics*. Acheson J. Duncan, Irwin, 1986. number of pages: 1123 (1989), 250-251.
<https://doi.org/10.1002/qre.4680050315>

Acknowledgement

The author would like to acknowledge the funding support for this research from Institute for Research and Community Service, Sam Ratulangi University, Manado, Indonesia.

Authors Contribution Statement

Jotje Rantung: Conceptualization, Investigation, Data collection, Writing original manuscript. Benny Maluegha: Procuring instruments, Investigation and data collection. Yan Tondok: Measurement and data interpretation and visualizations, Writing, review and editing. Gideon David Rantung: Software, Data curation, formal analysis, Writing, review and editing. The final manuscript has been read and authorized by all authors, who also pledge to take responsibility for every part of the work.

Funding

This research was funded by PNPB BLU 2024, Sam Ratulangi University, Manado, Indonesia.

Competing Interests

The authors declare that there are no conflicts of interest regarding the publication of this manuscript.

Data Availability

The data supporting the findings of this study can be obtained from the corresponding author upon reasonable request.

Has this article screened for similarity?

Yes

About the License

© The Author(s) 2025. The text of this article is open access and licensed under a Creative Commons Attribution 4.0 International License.